



14+



2



2,4m



1 = 2,4m
2 = 0,65m
3 = 2,51m

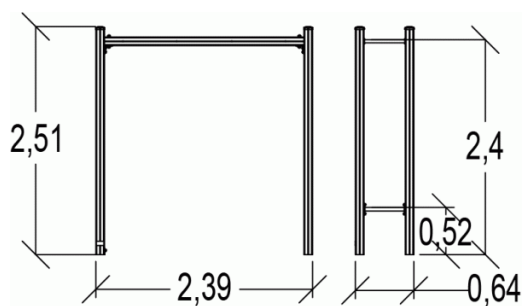
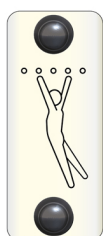

Ludieke functies : 3

Oversteken -
verplaatsen



x1

Hangen



x1

Pull-ups



x1

Installatie van het toestel

BELANGRIJK: raadpleeg de montagehandleiding voor de afmetingen van de veiligheidszones.

————— Veiligheidszone (minimale maatgevende oppervlakte)

- - - - - Vrije ruimte

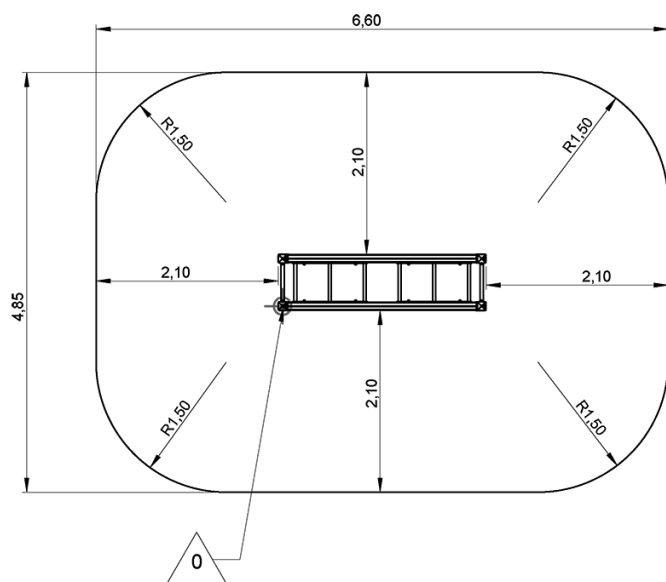

1	2,4m	30m ²



2



01h45



0.1m³



18m²



133kg



20kg

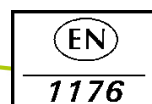



Sportformule

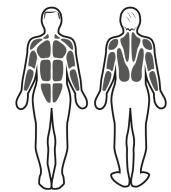

Spierstimulatie

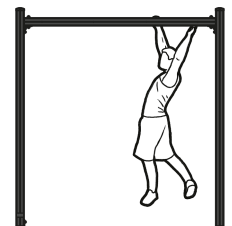

Bewegingen

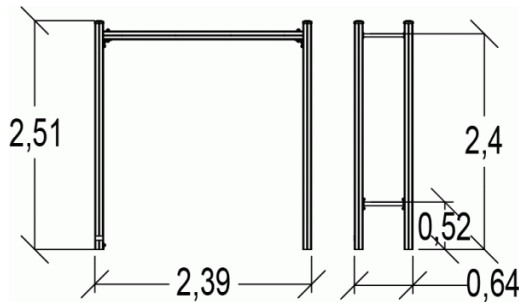

► **Sportieve activiteiten : 3**

Oversteken -
verplaatsen



x1

Hangen



x1

Pull-ups



x1

spierversterking



cardio

evenwicht



coördinatie

► Installatie van het toestel

BELANGRIJK: raadpleeg de montagehandleiding voor de afmetingen van de veiligheidszones.

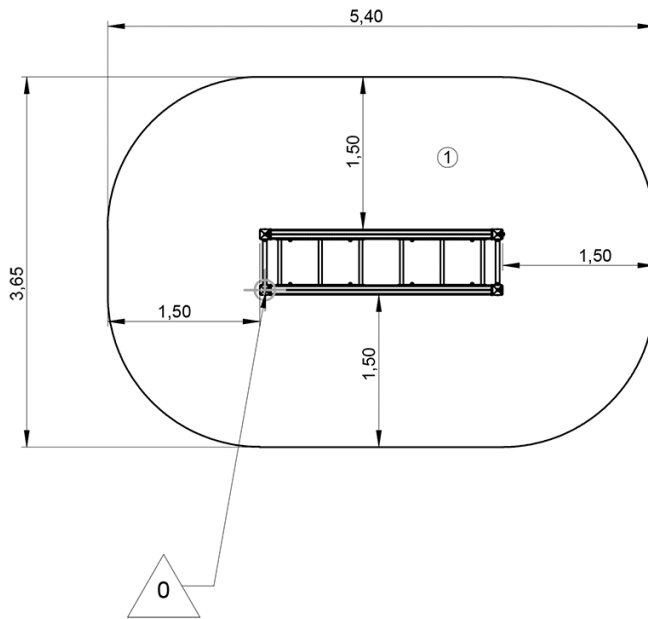
-  Veiligheidszone (minimale maatgevende oppervlakte)
-  Vrije ruimte



		
1	1,4m	18m ²



2



01h45



0.1m³



18m²



133kg



20kg

