



8+



2



1,7m



1 = 2,39m  
2 = 0,64m  
3 = 1,75m

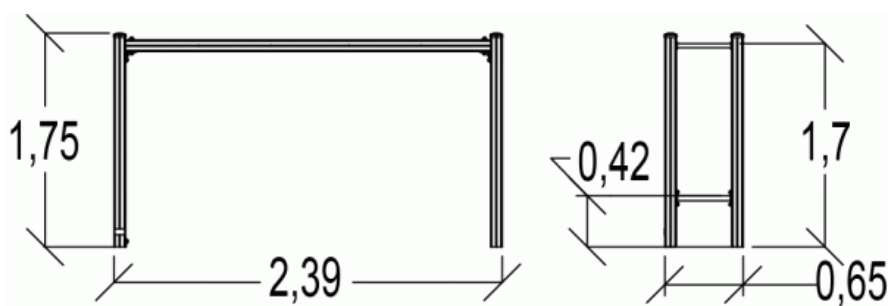
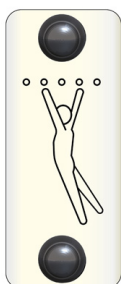

Ludieke functies : 3

Oversteken -  
verplaatsen



x1

Hangen



x1

Pull-ups



x1

## Installatie van het toestel

**BELANGRIJK:** raadpleeg de montagehandleiding voor de afmetingen van de veiligheidszones.

———— Veiligheidszone (minimale maatgevende oppervlakte)

- - - - - Vrije ruimte

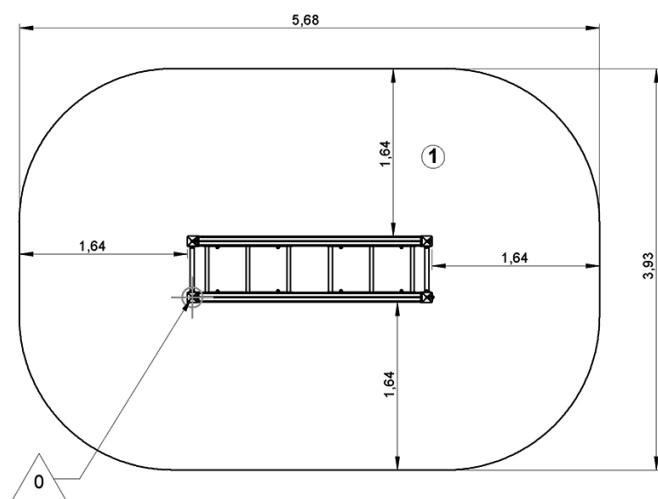

1	1,7m	20,5m <sup>2</sup>



2



01h45



0.1m<sup>3</sup>



18m<sup>2</sup>



112kg



15kg

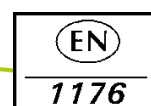



Sportformule

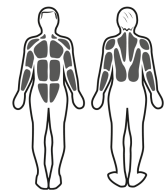

Spierstimulatie

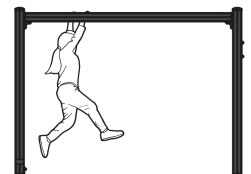

Bewegingen

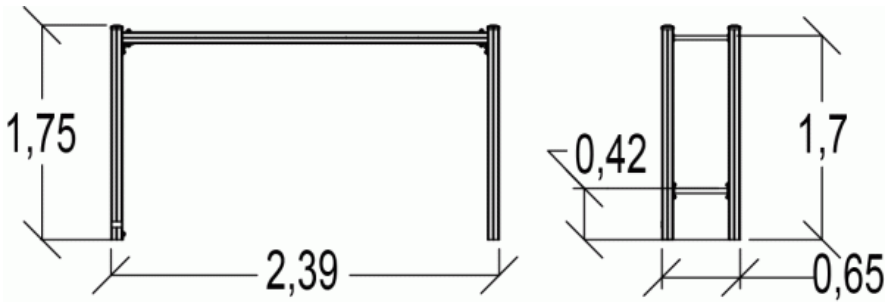

► **Sportieve activiteiten : 3**

Oversteken - verplaatsen



x1

Hangen



x1

Pull-ups



x1

spierversterking

cardio

evenwicht

coördinatie



## ► Installatie van het toestel

**BELANGRIJK:** raadpleeg de montagehandleiding voor de afmetingen van de veiligheidszones.

———— Veiligheidszone (minimale maatgevende oppervlakte)

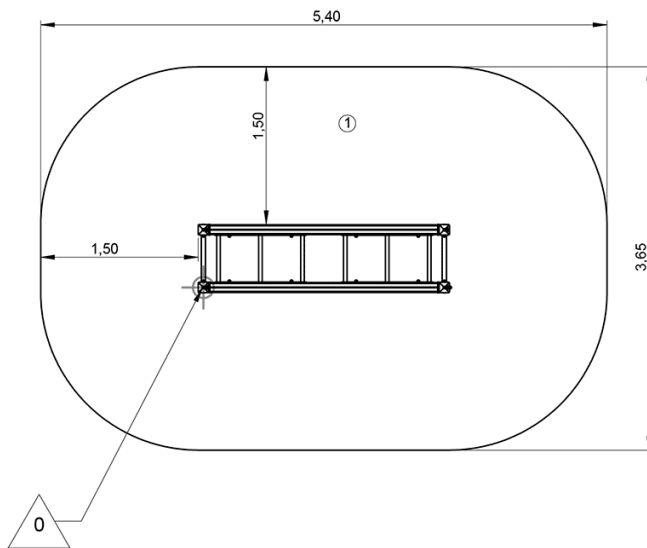
- - - - - Vrije ruimte



		
1	0,7m	18m <sup>2</sup>



2



01h45



0.1m<sup>3</sup>



18m<sup>2</sup>



112kg



15kg

