



14+



2



1,8m



1 = 2,3m
2 = 0,1m
3 = 2,02m

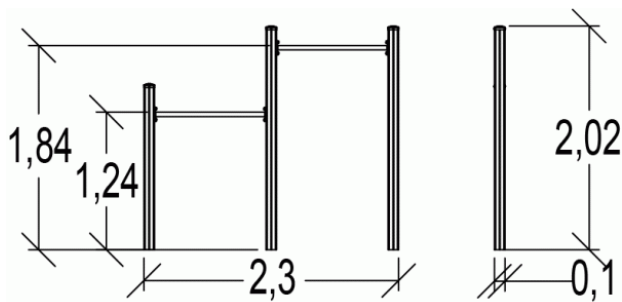

Ludieke functies : 4

Hangen



x2

Pull-ups



x2

Installatie van het toestel

BELANGRIJK: raadpleeg de montagehandleiding voor de afmetingen van de veiligheidszones.

———— Veiligheidszone (minimale maatgevende oppervlakte)

- - - - - Vrije ruimte

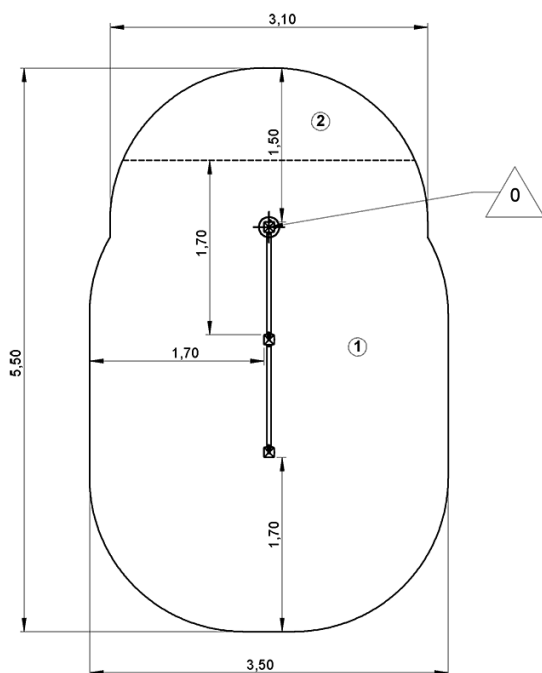

1	1,2m	2m ²
2	1,8m	15m ²



1

01h00

0.1m³

14.5m²

54kg

17kg

EN

1176



Sportformule

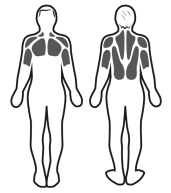

Spierstimulatie



Bewegingen

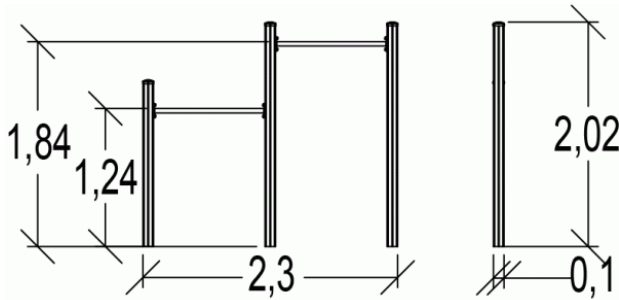

► **Sportieve activiteiten : 4**

Hangen



x2

Pull-ups



x2

spierversterking



cardio

evenwicht



coördinatie

► Installatie van het toestel

BELANGRIJK: raadpleeg de montagehandleiding voor de afmetingen van de veiligheidszones.

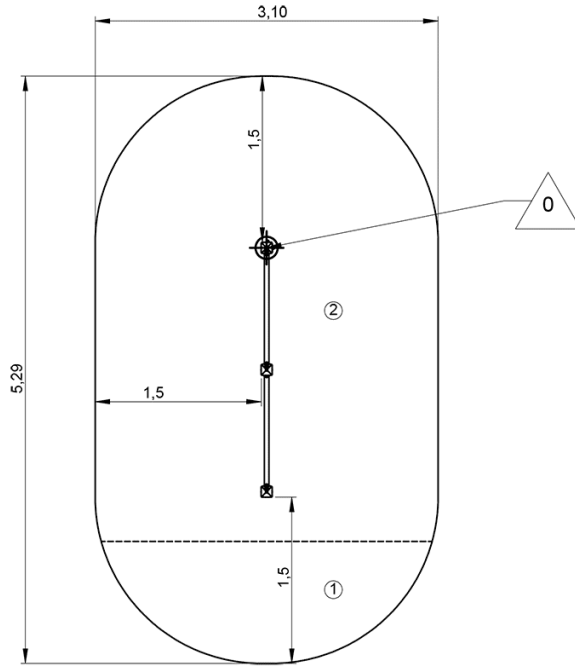
-  Veiligheidszone (minimale maatgevende oppervlakte)
-  Vrije ruimte



		
1	0,84m	3m ²
2	1,24m	12m ²



1



01h00



0.1m³



14.5m²



54kg



17kg

