



6+



36



2,32m



1 = 5,63m
2 = 2,53m
3 = 3,01m



Motorische inclusie
Zintuiglijke inclusie
Verstandelijke inclusie

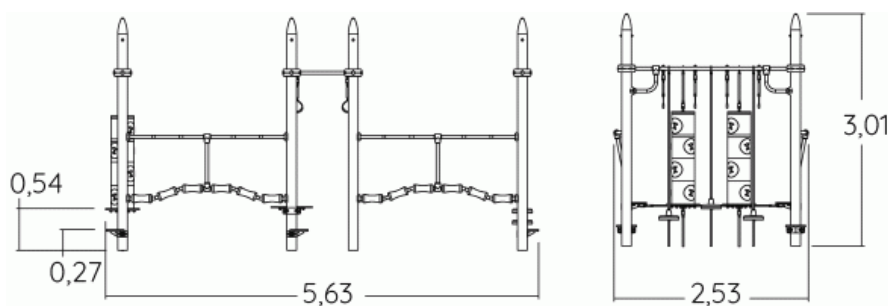

Ludieke functies : 19

Balanceren



x7

Oversteken -
verplaatsen



x9

Hangen



x3

Componenten

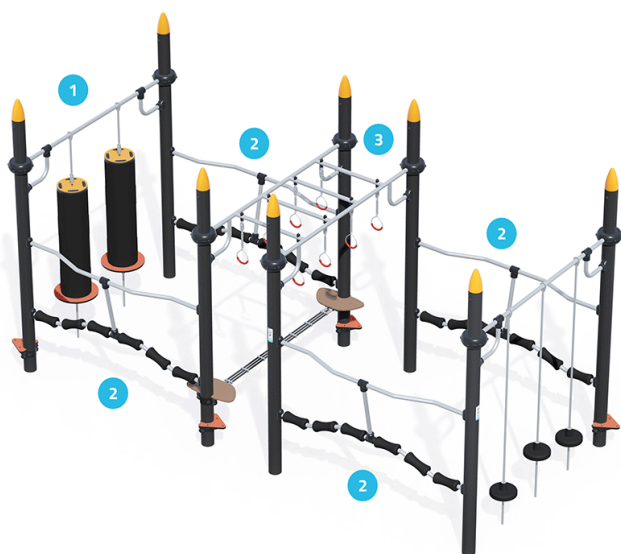

- ① Rouleaux suspendus
- ② Loopbrug kleine pasjes dalend
- ③ Passerelle anneaux
- ④ Plôts suspendus

Installatie van het toestel

BELANGRIJK: raadpleeg de montagehandleiding voor de afmetingen van de veiligheidszones.

- Veiligheidszone (minimale maatgevende oppervlakte)
- Vrije ruimte

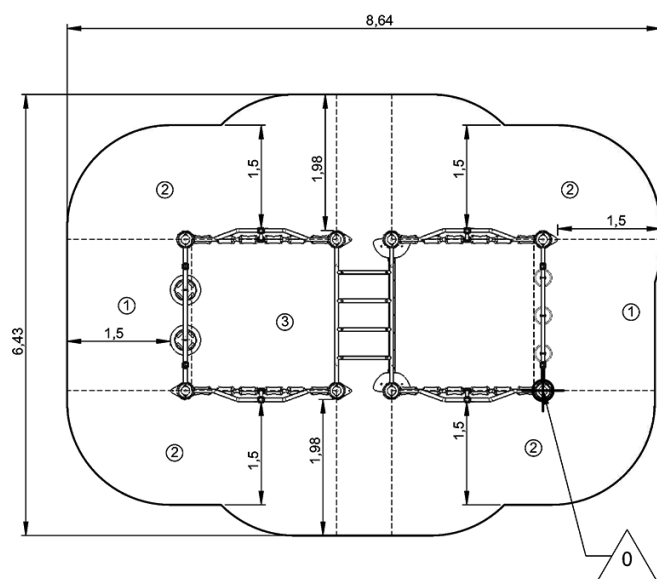

1	0,6m	8m ²
2	0,86m	27,5m ²
3	2,32m	14,5m ²



2

09h00

0.65m³

50m²

625kg

107kg

EN

1176



Sportformule

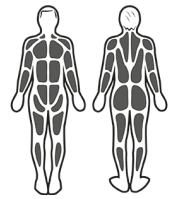

Spierstimulatie

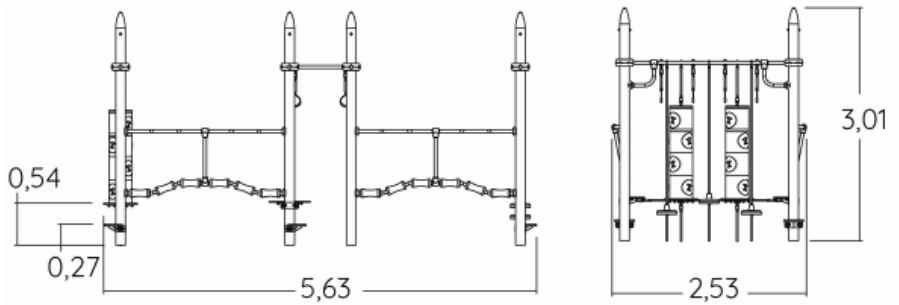

► Sportieve activiteiten : 19



spierversterking

cardio

evenwicht

coördinatie

Componenten

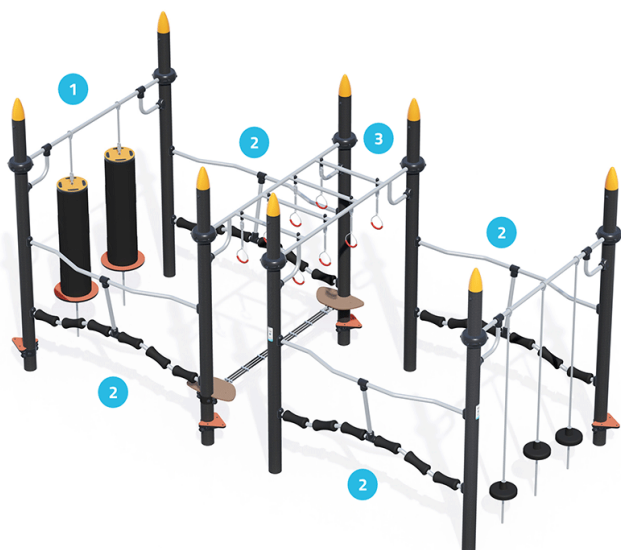

- ① Rouleaux suspendus
- ② Loopbrug kleine pasjes dalend
- ③ Passerelle anneaux
- ④ Plôts suspendus

Installatie van het toestel

BELANGRIJK: raadpleeg de montagehandleiding voor de afmetingen van de veiligheidszones.

- Veiligheidszone (minimale maatgevende oppervlakte)
- Vrije ruimte

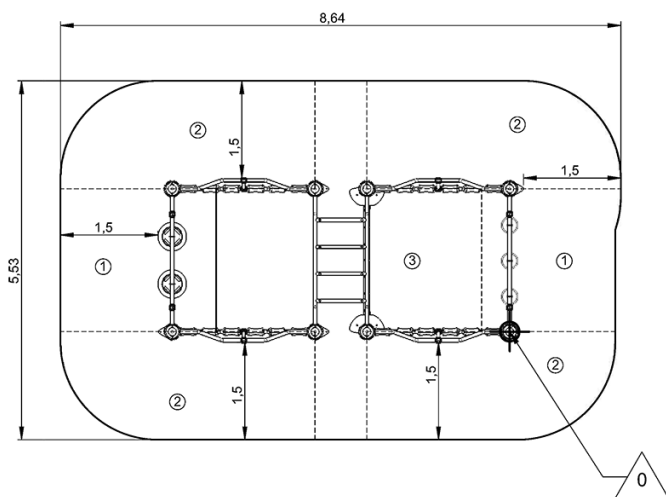

1	0,6m	10,5m ²
2	0,86m	25,5m ²
3	1,32m	12m ²



2



09h00



0.65m³



50m²



625kg



107kg

